

ECV Technical Data

High Lift Pallet Truck

ECV 10 C

ECV 10i C

ECV 10





				STILL	STILL	STILL		
Features	1.1	Manufacturer						
	1.2	Manufacturer's model designation		ECV 10 C	ECV 10i C	ECV 10		
	1.3	Drive		Electric	Electric	Electric		
	1.4	Operation		Pedestrian truck	Pedestrian truck	Pedestrian truck		
	1.5	Capacity/load	Q	kg	1000	1000 (1200) ¹	1000	
	1.6	Load centre distance	c	mm	600	600	600	
	1.8	Load distance	x	mm	805	805	795	
	1.9	Wheel base	y	mm	1126	1260	1240	
	2.1	Service weight		kg	462	520	598	
Weights	2.2	Axle load, laden		drive end/load end	kg	530/950	580/1140	596/1002
	2.3	Axle load, unladen		drive end/load end	kg	350/120	350/170	446/152
Wheels/chassis	3.1	Tyres			Polyurethane	Polyurethane	Polyurethane	
	3.2	Tyre size		drive end	mm	Ø 210 x 70	Ø 210 x 70	Ø 210 x 70
	3.3	Tyre size		load end	mm	Ø 80 x 60	Ø 80 x 60	Ø 80 x 60
	3.5	Number of wheels (x = driven)		drive end/load end		1x1/4	1x1/4	1x1/4
	3.6	Track width	b ₁₀ /b ₁₁	mm	533/380	533/380	533/370	
	Dimensions	4.2	Height of mast when lowered	h ₁	mm	1940	1940	2097
4.3		Free lift	h ₂	mm	1505	1480	150	
4.4		Lift	h ₃	mm	1517	1513	2927	
4.5		Height of mast when raised	h ₄	mm	1955	2090	3487	
4.6		Initial lift	h ₅	mm	-	115	-	
4.9		Tiller handle height in driving position	min./max.	h ₁₄	mm	800/1250	800/1250	800/1250
4.15		Fork height, lowered	h ₁₃	mm	88	88	88	
4.19		Total length	l ₁	mm	1615	1750	1740	
4.20		Length including fork backs	l ₂	mm	465	600	590	
4.21		Overall width	b ₁	mm	800	796	800	
4.22		Prong dimensions	DIN ISO 2331	s/e/l	mm	60/170/1150	60/190/1150	55/160/1150
4.24		Fork carriage width	b ₃	mm	680	680	600	
4.25		Overall fork width	b ₅	mm	550	560	560	
4.32		Ground clearance, centre of wheel base	m ₂	mm	28	26	30	
4.34		Working aisle width with pallet 800 x 1200 lengthways	A _{st}	mm	2100	2260	2219	
4.35	Turning radius	W _a	mm	1337	1500	1450		
Performance data	5.1	Driving speed		laden/unladen	km/h	4.0/4.5	4.0/4.5	4.5/4.8
	5.2	Lifting speed		laden/unladen	m/s	0.10/0.17	0.10/0.14	0.12/0.22
	5.3	Lowering speed		laden/unladen	m/s	0.20/0.13	0.20/0.13	0.20/0.13
	5.8	Max. gradeability		laden/unladen	%	3/10	3/10	3/10
	5.10	Service brake				Electromagnetic	Electromagnetic	Electromagnetic
Electric engine	6.1	Drive motor, rating S2 = 60 min			kW	0.65	0.65	0.65
	6.2	Lift motor, rating at S3 = 15%			kW	2.2	2.2	2.2
	6.3	Battery according to DIN 43531/35/36 A, B, C, no				No	No	No
	6.4	Battery voltage/rated capacity K _s			V/Ah	2x12/85	2x12/85	2x12/125
	6.5	Battery weight			kg	2x25	2x25	2x33
	6.6	Energy consumption according to VDI cycle			kWh/h	0.41	0.38	0.37
Misc.	8.1	Transmission control				DC control	DC control	DC control
	8.4	Noise level (at operator's ear)			dB(A)	74	74	74

¹ Transpallet capacity on the load arm

Mast Tables

ECV 10 C / ECV 10i C	Mono mast						
			ECV 10 C		ECV 10i C		
	Height	h ₁	mm	1940	2290	1940	2290
	Overall height with used free lift (h ₃ = 150 mm)	h ₁ '	mm	1940	2290	1940	2290
	Free lift	h ₂	mm	1505	1855	1480	1830
	Lift	h ₃	mm	1517	1867	1513	1863
Height, mast extended	h ₄	mm	1955	2305	2011	2361	

ECV 10	Telescopic mast							
			ECV 10					
	Height	h ₁	mm	1672	1772	1872	2022	2172
	Overall height with used free lift (h ₃ = 150 mm)	h ₁ '	mm	1747	1847	1947	2097	2247
	Free lift	h ₂	mm	150	150	150	150	150
	Lift	h ₃	mm	2227	2427	2627	2927	3227
Height, mast extended	h ₄	mm	2787	2987	3187	3487	3787	

ECV High Lift Pallet Truck
 Technical Drawings

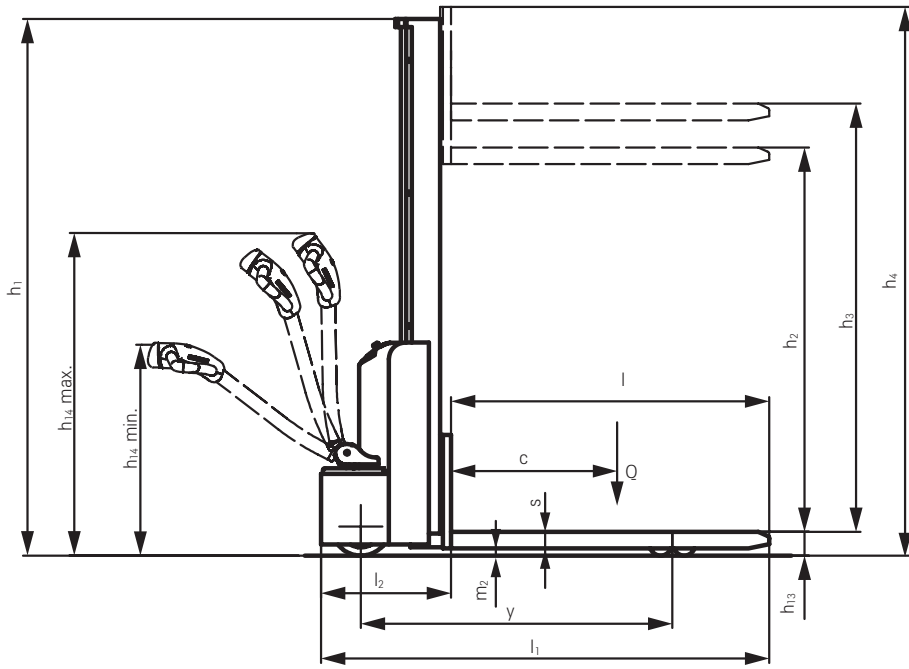

ECV 10 C side view

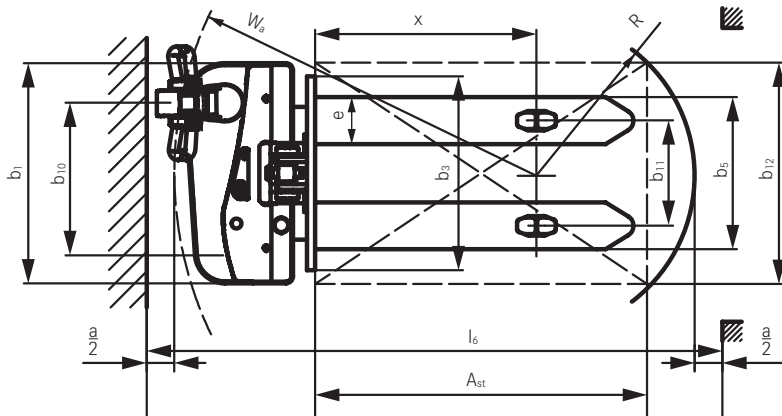

ECV 10 C top view

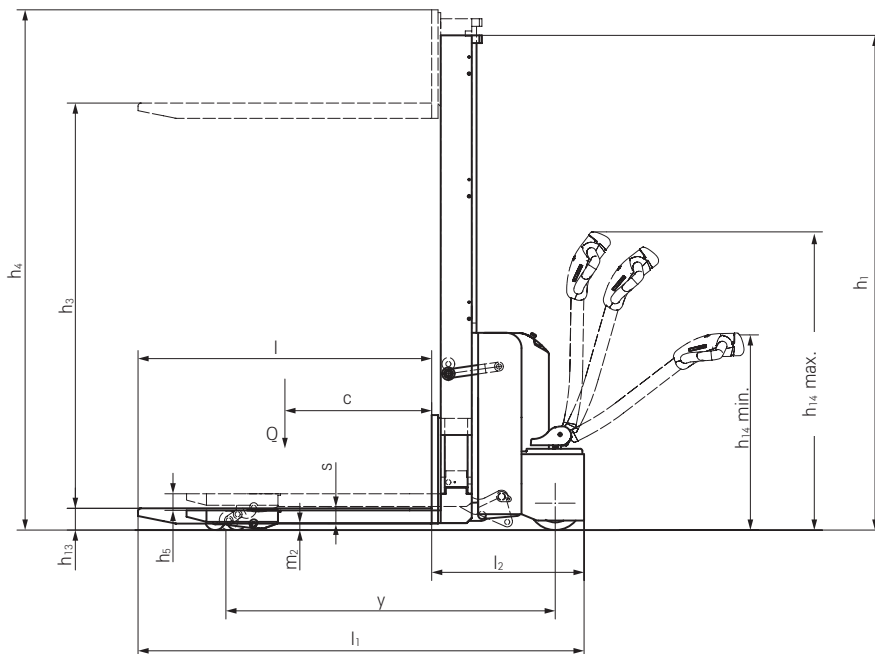

ECV 10i C side view

ECV High Lift Pallet Truck
 Technical Drawings

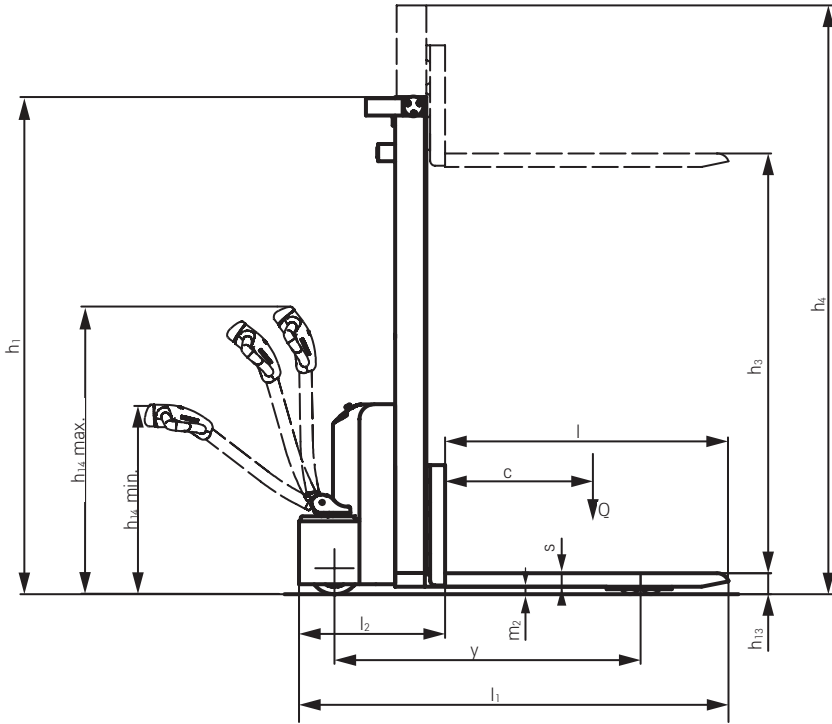

ECV 10 side view

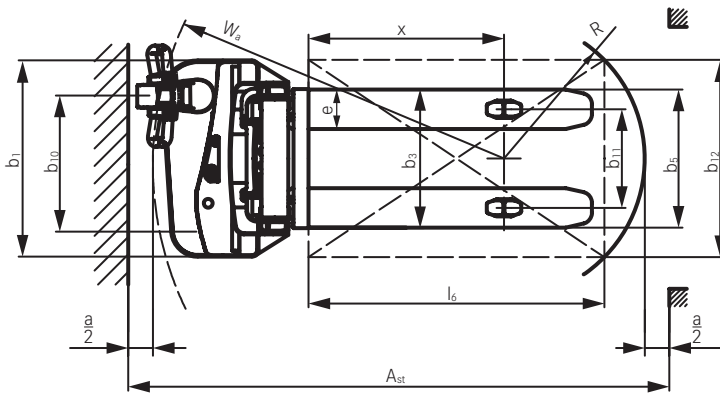

ECV 10 top view

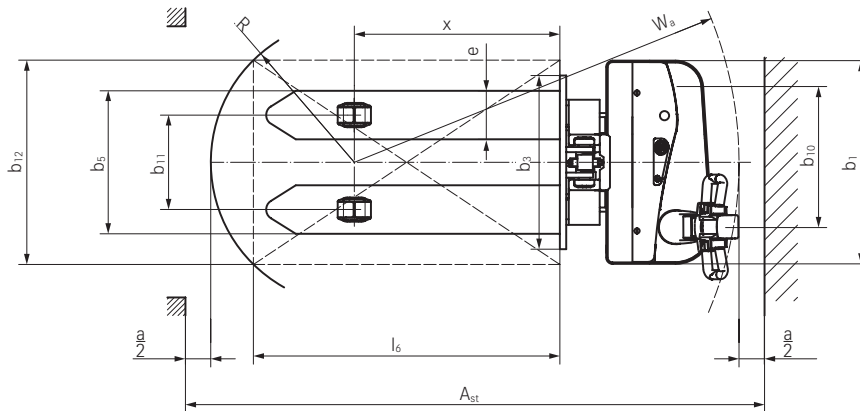

ECV 10i C top view

ECV High Lift Pallet Truck Detailed Photos



Fatigue-free operation thanks to easy-grip tiller for both left- and right-handed operators



Optimum stability thanks to four-wheel chassis



Built-in charger guarantees maximum availability and enables decentralised charging

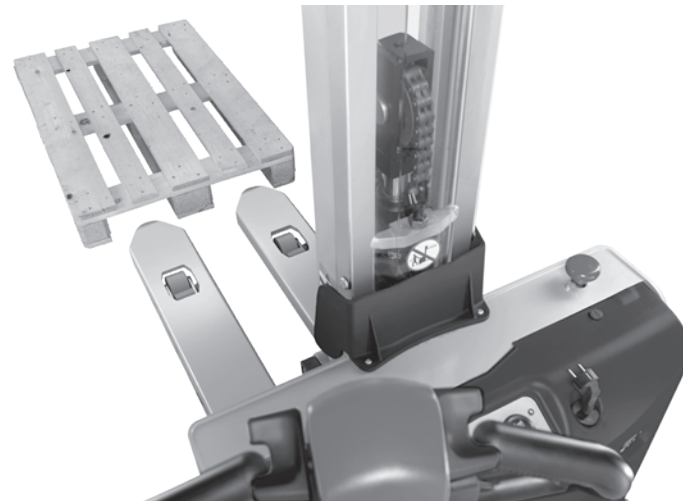

High turnover performance thanks to optimum view of the forks during stacking in racks



Lift heights of up to 3,227 mm enable a high degree of storage compression



Compact front end enables maximum manoeuvrability down even the narrowest of aisles

ECV High Lift Pallet Truck Detailed Photos

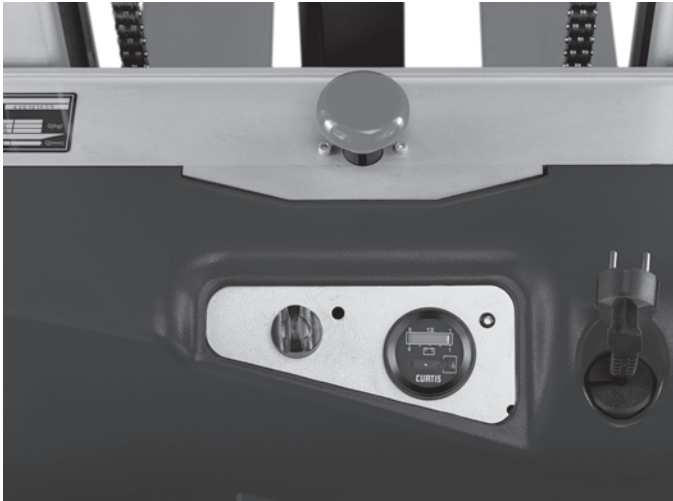

Everything in view at all times thanks to LED display with battery charge display and operating hours counter



Always safe when driving due to the speed reduction based on lift height



Bumps can be driven over with ease with optional initial lift for more ground clearance



Rounded fork tips for fast and precise threading into the pallets



Low frame construction for maximum operator safety



Low service weight enables it to be used on intermediate levels or in freight lifts

ECV High Lift Pallet Truck
Lifting Made Easy



ECV High Lift Pallet Truck
Lifting Made Easy



ECV High Lift Pallet Truck Lifting Made Easy

Flexible right down to the tips of the forks: Be it light stacking tasks up to 1,867 mm the use as a mobile workbench

Our most compact pallet stacker: Because of the extremely small front end it impresses even in the tightest working areas

Extremely high levels of safety: Low chassis frame and speed reduction based on lift height



ECV 10 C/ECV 10i C

Are you looking for a starter truck in the world of pallet stackers? Allow us to introduce the ECV 10 C. With a mono mast and a maximum lifting capacity of up to 1,000 kg it can be used for a wide range of applications. Whether being used for stacking applications up to 1,867 mm or to provide ergonomic support as a mobile workbench, the ECV 10 C is an all-rounder. The easy-grip tiller for left- and right-handed operators enables precise operation of all of the driving and lifting functions. The ECV 10 C also performs well in terms of availability because it always has the necessary amount of power thanks to its

built-in charger. The battery can be recharged conveniently and simply at any standard socket. And there is more: The ECV 10 C is our most compact pallet stacker and can master applications in the narrowest working areas with ease. The mono mast also provides the best possible view of the fork tips so the operator always has an overview and can thread them accurately into the pallets. The optional initial lift provides more ground clearance so uneven surfaces can be negotiated with ease.

High turnover performance: Lifting capacity up to 1,000 kg and lift heights up to 3,227 mm

Ultimate availability: Built-in charger enables easy charging

Manoeuvrable and compact: Small front end enables excellent manoeuvrability and usage in narrow aisles



ECV 10

Reaching new heights: With the ECV 10 you can reach a lift height of up to 3,227 mm. Paired with a maximum lifting capacity of up to 1,000 kg, the ECV 10 high lift pallet truck provides ideal support for light and sporadic stacking applications. The compact truck dimensions enable transporting and stacking even in tight working areas and narrow aisles. Easy charging? No problem – thanks to the built-in charger the ECV 10 can be recharged at any standard socket. The two 12 V batteries deliver 125 ampere hours. The LED display shows the

current battery charge status and the operating hours, so the operator always keeps an overview. The ECV 10 also performs well in terms of safety. The wide view between the lift profiles allows for an optimum view of the fork tips. In addition, the lowered design of the vehicle frame protects the feet of operators and third parties. The ECV 10 is also equipped with automatic speed reduction based on lift height, to keep you safe when driving. All functions can be operated with equal ease by left- and right-handed operators.

ECV High Lift Pallet Truck

The 'Simply Efficient' factors: Performance attributes as a measure of economic efficiency



Simply easy

- Optional initial lift to effortlessly negotiate inclines
- Low service weight enables smooth steering
- Both left- and right-handed users can intuitively operate all of the driving, lifting and lowering functions
- Tandem load rollers provide for smooth driving behaviour on uneven ground
- Low steering forces when manoeuvring relieve the stress on the operator



Simply powerful

- Effective goods handling thanks to a load capacity of up to 1,000 kg
- High degree of storage compression thanks to maximum lift heights of up to 3,227 mm
- Maintenance-free batteries protect operators and the environment



Simply safe

- Optimum stability thanks to four-wheel chassis
- Optimum view of the forks thanks to free view mast or mono mast
- Fatigue-free operation of all driving, lifting, and lowering functions for both left- and right-handed operators
- The low chassis frame protects the feet of operators and third parties in public areas
- The speed reduction based on lift height increases safety
- No battery gassing – this protects operators and the environment



Simply flexible

- Compact front end enables use in tight working areas and narrow aisles
- Possible use on mezzanine floors because of low load on the ground
- The built-in charger allows for flexible and decentralised charging of the forklift truck



Simply connected

- Battery charge display: Battery status is quick and easy to read so batteries can be charged in good time whenever necessary

Equipment Variants



		ECV 10 C	ECV 10i C	ECV 10
General	Electric lifting and driving	●	●	●
	High performance 0.65 kW drive motor	●	●	●
	Stable and robust frame design	●	●	●
	Easy-grip tiller for left- and right-handed operators	●	●	●
	LED battery charge display	●	●	●
	Operating hours counter	●	●	●
	Low positioned tiller	●	●	●
	Precise driving behaviour	●	●	●
	Four-wheel chassis for maximum stability	●	●	●
	Stabilising wheel	●	●	●
Mast	Initial lift	—	●	—
	Various mono masts	○	○	—
	Various telescopic masts	—	—	○
	Free view mast	●	●	●
Tyres	Protective mast screen made from polycarbonate	●	●	●
	Drive wheel tyres, polyurethane	●	●	●
	Drive wheel tyres, polyurethane, profiled	○	○	○
Safety	Load roller tyres, polyurethane, tandem	●	●	●
	Speed reduction based on lift height	●	●	●
	Low chassis frame for maximum operator safety	●	●	●
Battery	Access authorisation with key switch	●	●	●
	Maintenance-free AGM batteries	●	●	●
	Built-in charger	●	●	●
	Protection to prevent operator unintentionally driving while battery is charging	●	●	●

● Standard ○ Option — Not available

STILL GmbH
Berzeliusstr. 10
22113 Hamburg
Germany
Tel.: +49 40 73 39 20 00
Fax: +49 40 73 39 20 01
info@still.de

For further information please visit
www.still.eu

STILL is certified in the following areas: Quality management, occupational safety, environmental protection and energy management.

